

Office of Surface Water Protection
Operations & Maintenance Section

Regulatory Expectations For Wastewater Collection and Treatment Operations and Maintenance

Version: May 02, 2024



Regulatory Expectations for Wastewater Collection and Treatment Operations and Maintenance

Revision: May 02, 2024

Contents

- 1. Requirements For Reporting Sanitary Sewer Overflow/Bypass/RIPDES Max Daily Noncompliance /Disruption in Treatment..... 2
- 2. Site Cleanup following a Sanitary Sewer Overflow 3
- 3. RIPDES Weekly and Monthly Non-Compliance notification 3
- 4. Suggested notifications 4
- 5. Bacteria testing during SSOs, times of possible disinfection issues, and availability of 24-hour bacteriological sampling 4
- 6. Bacteriological sampling: Accuracy and dilutions 5
- 7. Split samples to check quality assurance..... 5
- 8. MOR/bioassay reporting..... 5
- 9. Reporting loads 5
- 10.NetDMR: resubmitting data 6
- 11.NetDMR: naming conventions 6
- 12.NetDMR: submitting attachments as PDF files 6
- 13.WWTF and Collection System Improvements 6
- 14.Primary and Backup Sludge Disposal Plans 7
- 15.Air Resources requirements 7
- 16.Standard Work Instruction Sheet 8

THIS DOCUMENT IS MEANT AS A HELPFUL SUMMARY AND EXPLANATION OF IMPORTANT REGULATORY EXPECTATIONS FOR THE OPERATIONS AND MAINTENANCE OF WASTEWATER COLLECTION AND TREATMENT INFRASTRUCTURE. THIS SUMMARY IS BASED ON FREQUENTLY ASKED QUESTIONS AND COMMON ERRORS OBSERVED BY DEM'S OPERATIONS & MAINTENANCE SECTION. IT IS NOT MEANT AS A COMPREHENSIVE LIST NOR DOES IT REPLACE A THOROUGH READING OF THE REGULATIONS AND PERMIT LANGUAGE.

WHEN REVIEWING THIS DOCUMENT, PLEASE CONTACT A MEMBER OF THE OPERATIONS & MAINTENANCE SECTION WITH ANY QUESTIONS.



Regulatory Expectations for Wastewater Collection and Treatment Operations and Maintenance

Revision: May 02, 2024

1. Requirements For Reporting Sanitary Sewer Overflow/Bypass/RIPDES Max Daily Noncompliance /Disruption in Treatment

Immediate notification to DEM: Please be reminded that the Regulations for the Rhode Island Pollution Discharge Elimination System ([250-RICR-150-10-1-14.R](#)) and the Rules and Regulations for the Operation and Maintenance of Wastewater Treatment Facilities ([250-RICR-150-10-4-5-A](#)) require **immediate verbal reporting to DEM of any noncompliance which may endanger health or the environment.** In addition, unless waived by DEM, a written report must also be provided, physically or electronically, to the Operations & Maintenance Section within five calendar days of the time the facility became aware of the circumstance. Finally, the noncompliance must also be reported as part of monthly DMR submissions.

E-Mail notification to DOT of SSOs: If your community experiences a sanitary sewer overflow that impacts a State DOT catch basin, you must also notify RIDOT via e-mail at DOT.IDDE@dot.ri.gov in addition to the DEM notification requirements. When notifying RIDOT, please provide your name, contact information, location of the SSO, and the location(s) of the impacted catch basin(s).

For the purposes of this requirement, noncompliance is defined as events denoted in the above-referenced regulations. These include:

- Sanitary sewer overflows, which is an intentional or unintentional discharge of raw or partially treated Wastewater from any point within a Wastewater Treatment Facility's collection system.
- Any bypass that results in the exceedance of any effluent limitation in the facility's RIPDES permit. Unless sampling data proves otherwise, the DEM will assume that all plant bypasses of final disinfection will exceed effluent limitations.
- A disruption in treatment that has the potential to result in an exceedance of any maximum daily effluent limitation in the facility's RIPDES permit. Such disruptions may include but are not limited to a final disinfection failure, evidence of the presence of incoming inhibitory substances, or solids washout.

Exceedances noted above that must be reported immediately are only those violations of a maximum daily discharge limitation for pollutants listed in the facility permit.

The immediacy of reporting is critical to the health and welfare of the State of Rhode Island. After you verbally notify DEM of an event, our office notifies our colleagues in DEM's Shellfishing section, the US EPA, the Rhode Island Department of Health, DEM management, and DEM public information staff so that appropriate statewide actions can be taken to protect public health and the environment. As such, please provide as much information as possible in the initial verbal report, with the understanding that additional information will also be provided as it becomes available. As such, please be reminded that failure to report non-compliance in accordance with state law and regulations may in itself be considered an enforceable event, which may include the forwarding of the matter to the Board of Certification of Operators of Wastewater Treatment Facilities for their review of any operator misconduct.

Because leaving emergency reports on voicemail is prohibited, DEM's administrative staff have been trained to take your verbal reports if you cannot connect with a member of the O&M section. When speaking with a member of DEM's administrative staff, you do not need to provide detailed information. Their role is simply to notify someone from the O&M section of the reported event, as well as basic information of the nature of the event and contact information. This applies to your calls to DEM's enforcement section, too, who have been trained to respond to your calls following the Standard Work "Script" on the final page of this document. As you may recall, this script provides guidance for both the caller and the DEM dispatchers on the content and order of that conversation.



Regulatory Expectations for Wastewater Collection and Treatment Operations and Maintenance

Revision: May 02, 2024

If you're speaking with a member of the dispatch unit after hours or an administrative staff member during business hours, it's suggested that you ask for their name. That will not only be helpful for your records but can assist DEM in the event of any concerns you have about ease of reporting.

The written report, to be submitted within 5 calendar days: If you are required to submit a written report as a result of a sanitary sewer overflow or a plant bypass, you must use the NeT-SewerOverflow web-based system that allows RIPDES permittees and wastewater collection system owners to electronically sign and submit their written reports of SSOs to DEM via a secure internet connection. For more information, please visit our DEM wastewater facility website (<https://dem.ri.gov/environmental-protection-bureau/water-resources/permitting/wastewater-treatment-facilities>) under the link "Reporting a Sewage Overflows." Remember that the written report is required to be submitted to the DEM within five calendar days of the time the Facility became aware of the circumstance.

2. Site Clean-up following a Sanitary Sewer Overflow

DEM has previously notified communities that emergency chlorination should not be utilized for disinfection during active SSOs that are impacting surface waterbodies. DEM does, however, expect communities to perform clean-up of the overflow site if possible.

Site clean-up guidance includes:

- Make every effort to remove as much debris as reasonably possible from streets/sidewalks/driveways, and other paved surfaces. If possible, manually remove sewerage debris from discharge locations and transport to a disposal site.
- Contain wash water and prevent it from impacting surface waterbodies.
- Disinfectant may be applied to impacted impervious surfaces in public areas where human contact may occur (streets and structures in the vicinity of the release). Areas should be rinsed, and the rinse water should be returned to the sewer. Do not use disinfectant if it may enter catch basins that cannot be fully recovered before entering a surface waterbody.
- Lime can be spread over pervious surfaces to kill pathogens and control odors.
- If the overflow reached a catch basin, pump out standing wastewater from the catch basin and discharge into the sanitary sewer system. If the catch basin is owned by RIDOT, contact them as described above for additional clean up guidance.

3. RIPDES Weekly and Monthly Non-Compliance notification

24-hour reporting to DEM: DEM has regularly reminded superintendents of the requirement to report *all known weekly and monthly permit violations* to this office within 24 hours of becoming aware of a violation. Such notification is required under Part II(l) of your RIPDES permit and previously noted Rule 14.R of the Regulations for the Rhode Island Pollution Discharge Elimination System.

As with Item 1, requirements for notification exist so that this agency, in conjunction with the Department of Health, can take necessary and timely steps to protect public health and the environment.



Regulatory Expectations for Wastewater Collection and Treatment Operations and Maintenance

Revision: May 02, 2024

4. Suggested notifications

It is also encouraged, but not required, that facilities/communities update DEM should there be a planned or unplanned reduction of process equipment availability, even if such reductions do not result in permit non-compliance, or a planned flow diversion. In general, it's always helpful to keep DEM's Operations and Maintenance Section aware of significant changes in plant or collection system status even if no process issues are expected.

5. Bacteria testing during SSOs, times of possible disinfection issues, and availability of 24-hour bacteriological sampling

While DEM must take all necessary, timely, and prudent steps to protect public health and the environment in the event of a discharge of raw or partially treated sewage, it also wishes to avoid unnecessary advisories or shellfish closures that will impact the use of public waters—especially the shellfishing industry and its consumers—as well as the reputation of your facility and staff. Without adequate data about impacts to state waters as a result of an SSO or a failure at your wastewater treatment facility, DEM must assume a “worst case scenario” and take action based on that assumption to protect public health.

To prevent unnecessary shellfish closures or other advisories, the DEM has in the past required increased levels of monitoring for fecal coliform and (if required by your permit) enterococci during a failure at your plant or as a result of an SSO that discharges to state waters.

Authority for this requirement comes under Part 4.10 D and E of the Rules and Regulations for the Operations and Maintenance of Wastewater Treatment Facilities (250-RICR-150-10-4).

Therefore, please be advised that *in the event of evidence of inadequate disinfection at your facility or in the event of an SSO that is likely to impact state waters, bacteriological samples must be taken for those parameters required by your RIPDES permit.* DEM will provide specific guidance for sampling and reporting on a case-by-case basis. However, should you be unable to speak with a DEM official for such guidance, the default protocol is to sample and test for fecal coliform and (if required by your permit) enterococci at the following times:

- (i) at the initial determination that there is evidence of inadequate disinfection,
- (ii) approximately one hour after the attempted correction of the cause of inadequate disinfection,
- (iii) and at least daily should the cause of inadequate disinfection remain unresolved

No sampling should be attempted if there is a reasonable threat to operator safety.

Again, so that DEM can make timely and prudent determinations regarding public health advisories, samples must be tested with a sufficient number of dilutions (see item 6 below) to achieve meaningful results. Moreover, analysts must employ methods such as the A1 modified method which provide a result in 24 hours. All results must be reported to DEM. As such, it is in your facility's best interest to initiate and maintain ongoing communication with the DEM during such events.

Please be reminded that wastewater treatment facilities which use contract laboratories for bacteria sampling must have the option to collect and sample for bacteria during the nighttime and weekends. The DEM notified the wastewater community of this requirement in December 2005. As such all facilities should confirm and review their procedures—whether internal or contractual—for the testing of bacteria within the prescribed holding time.



Regulatory Expectations for Wastewater Collection and Treatment Operations and Maintenance

Revision: May 02, 2024

Please be notified that failure to determine a bacteria count during a condition of actual or suspected disinfection failure (that is, actual or assumed due to alarm conditions, etc.) will require the Department to assume a worst-case scenario of 24 million MPN/100 ml for a bacteria count.

6. Bacteriological sampling: Accuracy and dilutions

The EPA-approved "MPN" method for bacteriological analysis allows, as a minimum, 5 tubes and 3 dilutions for the testing and calculation of the fecal coliform concentration, which yields a maximum result of 1,600 MPN/100ml. The Department urges facilities to expand the number of dilutions as needed so that a more accurate fecal count can be attained. Should the number of dilutions only result in the determination of ">1,600 MPN/100ml," DEM will assume a worst-case of 24 million MPN/100 ml.

7. Split samples to check quality assurance

DEM suggests that facilities perform split samples with other laboratories in the event of three consecutive sampling results (such as for fecal coliform or enterococci) that indicate unexpectedly high values, especially if other pollutants are not elevated. Split sampling with another laboratory may assist you in determining the possibility of quality assurance issues with your current laboratory.

8. MOR/bioassay reporting

Permittees are required to submit monitoring data electronically to DEM in discharge monitoring reports (DMRs) using NetDMR. DMRs must be submitted no later than the 15th day of the month following the month for which the data is being submitted. *Hard copies of DMRs should not be submitted to DEM.* The permittee must also electronically submit copies of documents that are directly related to the DMR using NetDMR. These may include the following: DMR Cover Letters, Below Detection Limit summary tables, Wet Weather Event Summary Reports, and Monthly Operating Reports. Hard copy reports submitted to the DEM should include a cover letter describing the submission. Hard copy reports shall be signed and dated originals. Since DEM is phasing in electronic reporting for many types of reports, check your permit for which reports are required to be submitted electronically versus in hard copy. This includes written notifications required under Part II of your permit; Priority Pollutant Scan results; Infiltration/Inflow Reports; Pretreatment Reports, etc. Note that as of winter 2024, sewer overflows for all permittees are required to be submitted electronically using NeT-SewerOverflow as described previously in Section 3.

9. Reporting loads

When calculating the pollutant load, use the following formula:

Load (lbs/day) = Concentration (mg/l) x Flow (MGD) x 8.34 (a conversion factor)

Use each sample concentration and multiply it by the flow on the day that the sample was taken and by the conversion factor. The monthly average is calculated using each individual day's loading. For the sole purpose of calculating pollutant loads in lb/day, if the concentration value is less than the detection limit, use the detection limit in mg/l in the loading calculation shown above, not zero.



Regulatory Expectations for Wastewater Collection and Treatment Operations and Maintenance

Revision: May 02, 2024

10. NetDMR: resubmitting data

If you must resubmit data using NetDMR, please include a brief cover letter (one or two sentences will do) to explain what data you are updating. As NetDMR completely rewrites such data, DEM and EPA are otherwise unable to easily determine the nature of your changes.

11. NetDMR: naming conventions

In order to standardize the way reports are named when submitted as an attachment using NetDMR, each report should use the following convention consisting of the RIPDES permit ##, the Report Type Name (see below), and the year and month the report covers:

RIPDESPermit#_ReportTypeName_YYYY_MM

Report Name	Report Attachment Naming
CSO Report	PERMITID_CSO_YYYY_MM
DMR Cover Letter	PERMITID_DMRCov_YYYY_MM
Monthly Operating Reports	PERMITID_MOR_YYYY_MM

For example, if the Woonsocket WWTF was submitting its monthly operating report for July of 2021 as an attachment, the report name would be: RI0100111_MOR_2021_July

12. NetDMR: submitting attachments as PDF files

DEM prefers that attachments be submitted in PDF format. If possible, you should submit PDFs that are software-generated rather than paper scans (with the exception of signed cover letters). Monthly Operating Reports (MORs) may be submitted as an Excel file. Some facilities scan their MORs because the superintendent signs or initials each page of the MOR. DEM does not require such signing or initialing of MORs if submitting electronically through NetDMR.

13. WWTF and Collection System Improvements

Any improvements to wastewater treatment and collection system equipment require an Order of Approval from DEM’s Wastewater Planning & Design program for design and construction. The Order of Approval must be obtained prior to construction. Projects that involve the replacement of existing equipment with the same or “in-kind” equipment are not subject to DEM approval, provided the new equipment does not change or affect hydraulic and/or treatment capacity. If there are questions regarding whether approval is required, contact a member of the Operations and Maintenance Section or the Wastewater Planning & Design program for a determination. Please also be aware that any proposed collection system sewer extensions with an average daily design flow of greater than 30,000 gpd requires an Order of Approval from DEM. This includes municipal and private sewers and pump stations. Additional information on the Wastewater Planning & Design Program can be found on DEM’s website here: <https://dem.ri.gov/environmental-protection-bureau/water-resources/permitting/wastewater-treatment-facilities-planning-design>.



Regulatory Expectations for Wastewater Collection and Treatment Operations and Maintenance

Revision: May 02, 2024

14. Primary and Backup Sludge Disposal Plans

Please be reminded that wastewater managers should regularly review their facility's primary sludge disposal plans for accuracy and, if necessary, submit updated plans to DEM for review and approval.

As part for this review, wastewater managers are expected to confirm that the information within the most recently approved Application for Order of Approval remains up-to-date and accurate. Examples of such a confirmation include sludge transporter information and the transporter's ability to perform, as well as the viability of the facility's backup disposal plans and procedures, as discussed below.

Please note, every facility is **required** to have a backup/contingency disposal option to complement its primary disposal method(s).

Such backup plans are especially important considering current stresses on regional and local sludge disposal options. As such, facility managers are expected to review their backup options and update them, as necessary. Note that using the RI Resource Recovery Corporation landfill as backup alone may no longer be a consistently available option and plants should consider additional options.

Facility management must ensure that sludge transporters listed in the Application for OA are up to date. Should a change in transporters be needed, facility managers must submit an updated Applications for an Order of Approval.

Last, DEM strongly encourages every WWTF manager to maintain an ongoing review and analysis of—as well as respond to changes in—local and regional sludge transportation, capacity, and disposal options.

15. Air Resources requirements

The following two reminders are requirements of DEM Office of Air Resources, per 250-RICR-120-05-17 (“Odors”):

- Odors detected outside of your property line that result from the operations of wastewater collection or treatment systems are a violation per Rule 9 of DEM's Operations and Maintenance Regulations ([250-RICR-150-10-4](#)) and Rule 17 of DEM's Air Pollution Control Regulation ([250-RICR-120-05-17](#)). (This Rule is repeated in Part 4.9 of the Rules and Regulations for the Operations and Maintenance of Wastewater Treatment Facilities.)
- Any emergency generator where the engine is 50 HP or larger (heat input capacity of 350,000 BTUs or more per hour) and started up on or after November 15, 2007 requires a permit from the DEM's Office of Air Resources prior to installation. Please note that most new emergency generator installations might be eligible for a General Permit, which involves an administratively simpler permitting process than the minor source permitting process in DEM's Air Pollution Control Regulation No. 9. For more information about the permitting requirements for emergency generators contact DEM's Office of Air Resources at 222-2808.

Seq. No		Process Name: WWTF Call To DEM Law Enforcement FOR USE DURING NON-BUSINESS HOURS	Standard Work Instruction Sheet		
			SWIS #	DEM-DLE-001	REV # 3
ELEMENTS OF OPERATION			JOB LAYOUT (details)		

1	WWTF: CALL DEM DISPATCH 401-222-3070
2	WWTF: When Dispatcher answers, inform dispatcher "This is a Wastewater Event Call from (Name of Facility/Community). My name is (state your full name) and the contact number is (provide a phone number that can be called if additional information is needed). The event is a (provide one of the call category titles in boxes 4, 5, or 6.)"
3	DISPATCHER: Ask the numbered questions in the appropriate call-reason box. Note: Caller may not have all information, in which case record the information as "Unknown." OTHER SEWERAGE CALLS USE SEPTIC SYSTEM OVERFLOW & VIO (Code: ISDS)
4	FOR A SEW. PLANT DISCHARGE: Dispatcher questions: 1. "What is the nature of the process or equipment failure?" 2. "What is the approximate start time and end time, if known?" 3. "Are you reporting known permit violations, if so, what are they?" 4. "What is the approximate flow volume of any partially or untreated discharge?" (End questions: Go to Box 8)
5	FOR A SEW. COLLECTION SY. DISCHARGE: Dispatcher questions: 1. "What is the location of the event?" 2. "What is the approximate start time and end time, if known?" 3. "What water bodies, if any, are impacted?" 4. "What is the estimated volume or flow rate, if known?" (End questions: Go to Box 8)
6	FOR A SEW. PLANT PERMIT VIO: Dispatcher questions: 1. "What is the parameter violated?" 2. "What is the approximate numerical value and unit?" 3. "Is this violation the result of a plant failure?" 4. "If yes, please briefly explain." (End questions: Go to Box 8)
7	IF UNSURE OF CATEGORY, USE: SEW. DISCHARGE OTHER: Dispatcher questions: 1. "Nature of violation or issue." 2. "What water bodies, if any, are impacted?" 3. "What is the estimated volume or flow rate?"
8	WWTF: Ask for the name of the dispatcher.
9	DLE/WWTF: End call.

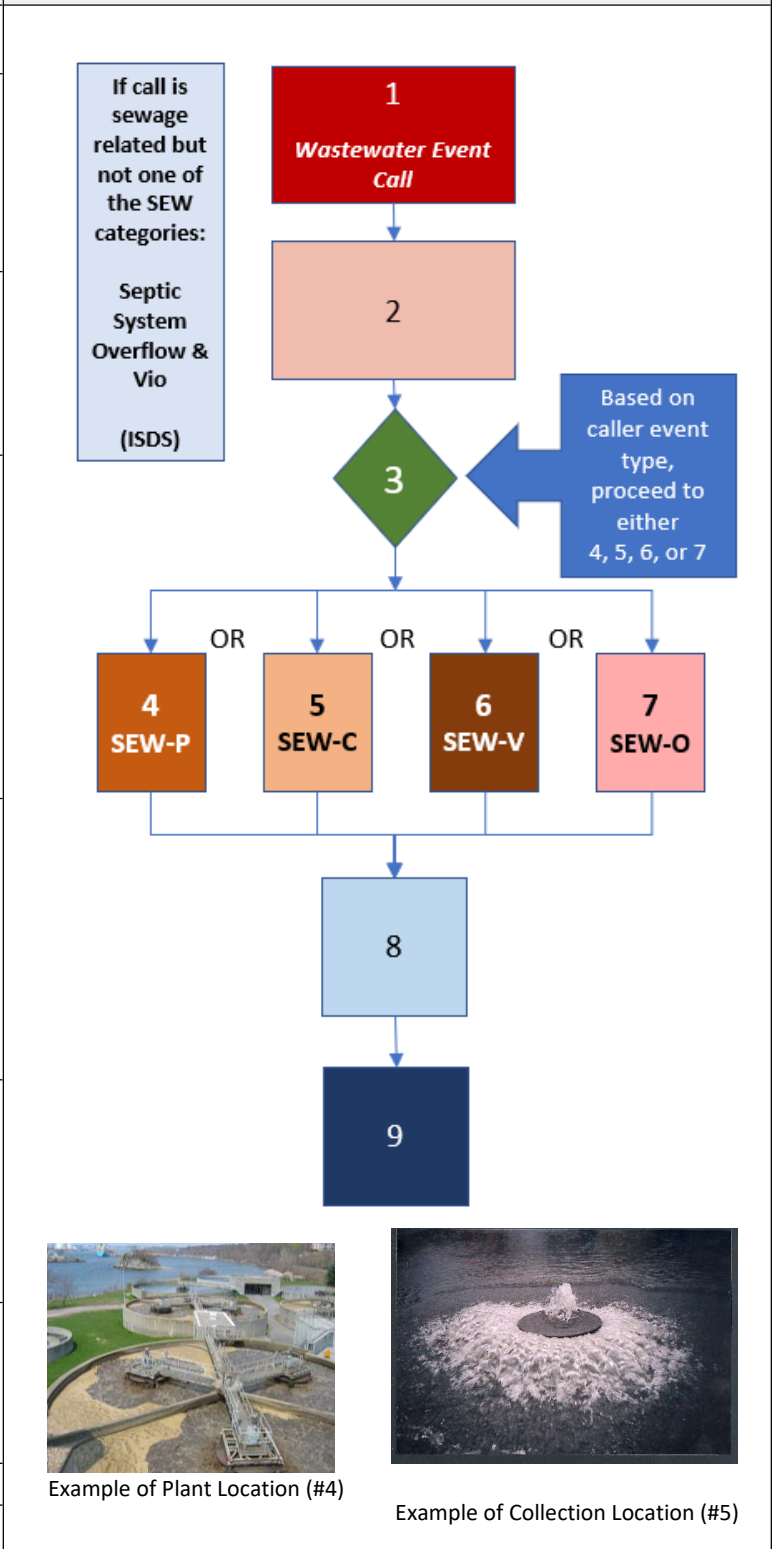

REQUIRED SKILLS	Effective Date:	TBD	Revisions Highlighted in Yellow
	Author:	Bill Patenaude	
	Supervisor Approval:	Steve Criscione	Page 1 of 1
	Lean Team Approval:	Lou Maccarone	